

THIRD ANNUAL

JUNE 11 - 13, 2018



## Developments in Small Modular Reactor Technology

Peter Lang



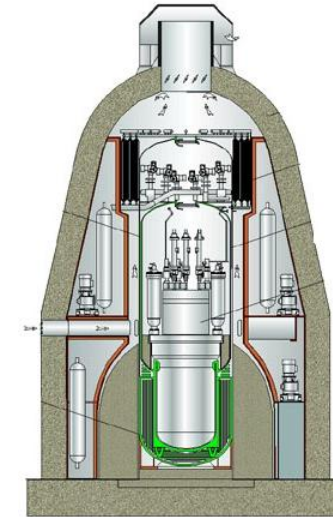
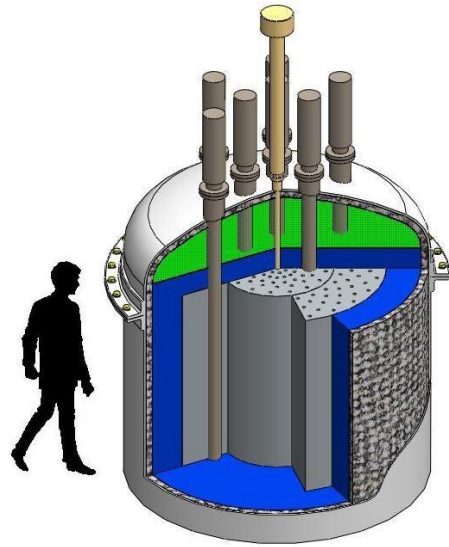
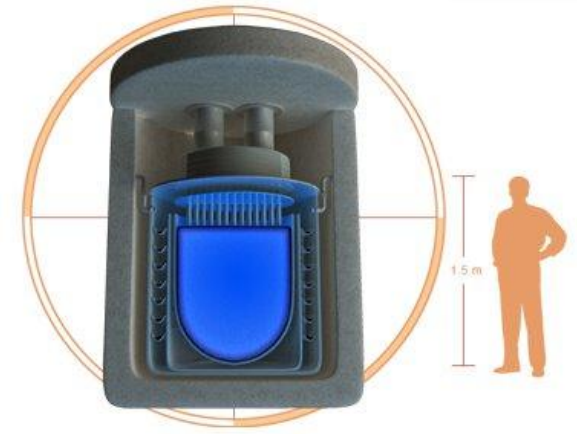
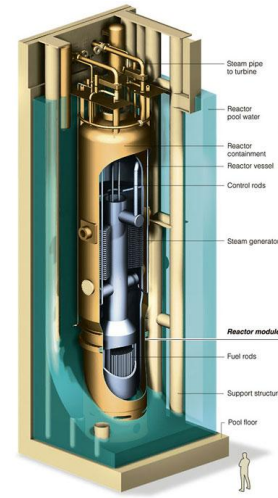
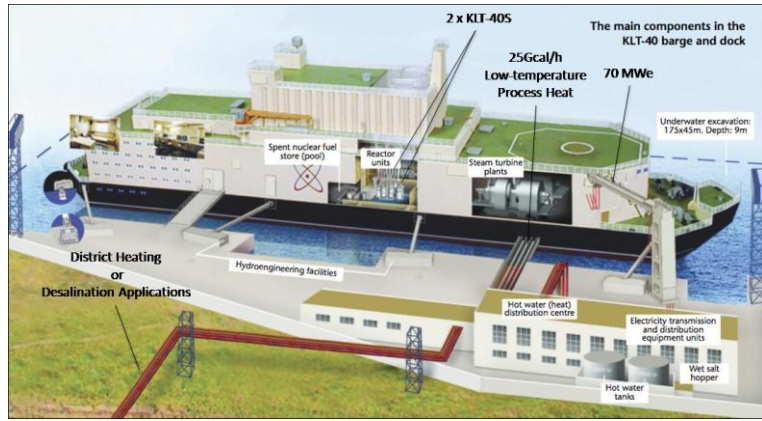

*We will never compromise safety*  
*Nous ne compromettrons jamais la sûreté*



Canadian Nuclear  
Safety Commission

Commission canadienne  
de sûreté nucléaire

Vendor	Name of design and cooling type	Approximate electrical capacity (MW electrical)	Applied for	Review start date	Status
Terrestrial Energy Inc.	IMSR Integral Molten Salt Reactor	200	Phase 1	April 2016	Phase 1 complete
			Phase 2	November 2017	Service agreement under development
Ultra Safe Nuclear Corporation / Global First Power	MMR-5 and MMR-10 High Temperature Gas	5-10	Phase 1	December 2016	Assessment in progress
LeadCold Nuclear Inc.	SEALER Molten Lead	3	Phase 1	January 2017	Phase 1 on hold at vendor's request
Advanced Reactor Concepts Ltd.	ARC-100 Liquid Sodium	100	Phase 1	Fall 2017	Assessment in progress
URENCO	U-Battery High-Temperature Gas	4	Phase 1	Tentative Spring 2018	Service agreement under development
Moltex Energy	Moltex Energy Stable Salt Reactor  Molten Salt	300	Series Phase 1 and 2	December 2017	Assessment in progress
SMR, LLC. (A Holtec International Company)	SMR-160 Pressurized Light Water	160	Phase 1	To be determined	Service agreement under development
StarCore Nuclear	StarCore Module High-Temperature Gas	10	Series Phase 1 and 2	To be determined	Service agreement under development

# Ottawa unveils road-mapping process for exploring small modular reactors

February 23, 2018   
By [Anthony Capkun](#)



Bruno Pereira. Photo courtesy Qulliq Energy Corp.

February 23, 2018 - NRCan announced a "road-mapping process" under the Energy Innovation Program to explore the potential for on- and off-grid applications for small modular reactor (SMR) technology in Canada.

"The nuclear industry in Canada is a vital source of innovation, job creation and low-carbon energy," says the federal ministry, adding, "The next generation in nuclear technology will help Canadians build a cleaner, safer world while meeting our energy needs in a low-carbon economy."

According to [NRCan](#), the road-mapping process will be delivered by the [Canadian Nuclear Association](#); it will engage stakeholders to get their views on priorities and challenges related to the possible development and deployment of SMRs, which includes looking at different SMR tech and how it aligns with user requirements and "Canadian priorities".

"[Qulliq Energy Corp.](#) is pleased to participate in a Canadian effort to establish a roadmap for small modular reactors," said Bruno Pereira, president of Nunavut's only generator and distributor of electricity. "Establishing a pathway for the implementation of SMRs is an important national issue with particular significance for remote communities that are interested in exploring alternative energy options."

**SEE ALSO** [U.S. DoE leading nuclear energy renaissance.](#)

Participation in the roadmap will eventually expand to include all essential enabling partners, including manufacturers, research performers, waste management organizations and the Canadian Nuclear Safety Commission.

"The roadmap will be an important step in positioning Canada to advance next-generation technologies and become a global leader in the emerging SMR market," NRCan added.

# Renewable Energy Sources and Climate Change Mitigation

## Special Report of the Intergovernmental Panel on Climate Change

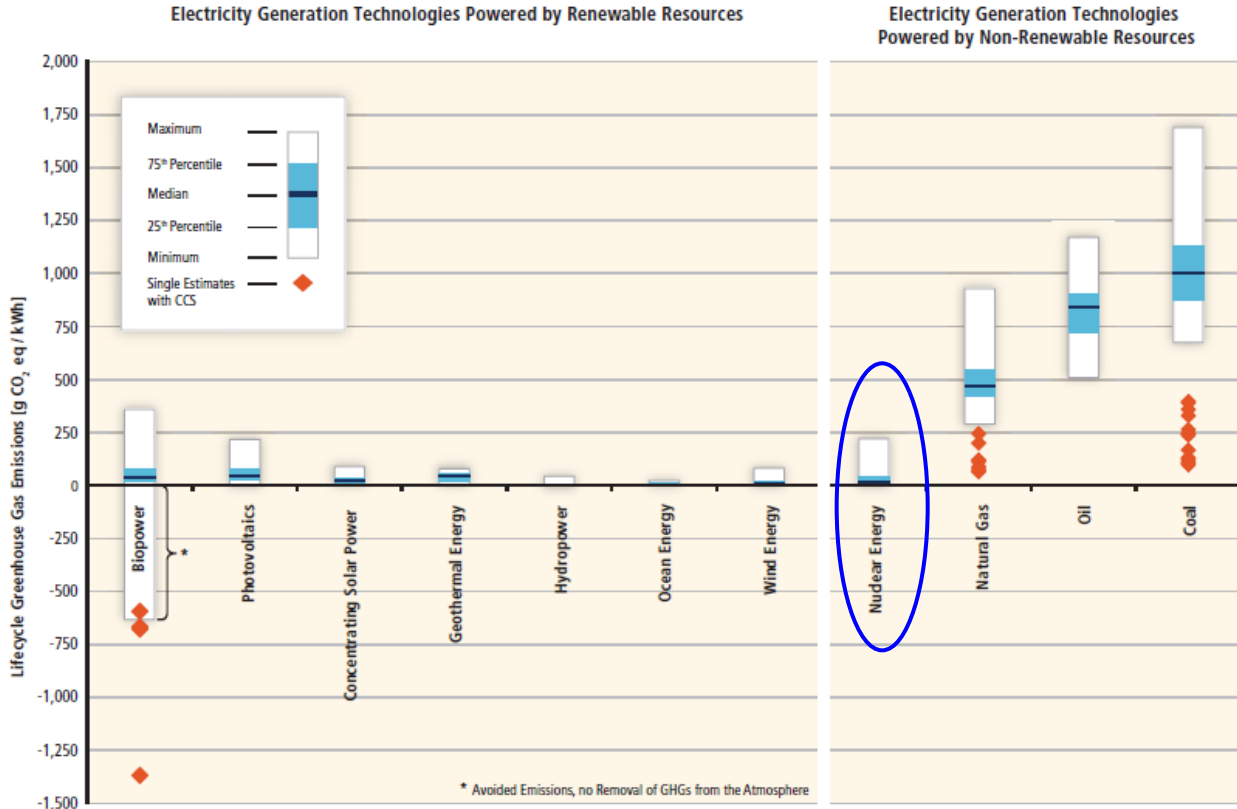

### Electricity Generation Technologies Powered by Renewable Resources

### Electricity Generation Technologies Powered by Non-Renewable Resources

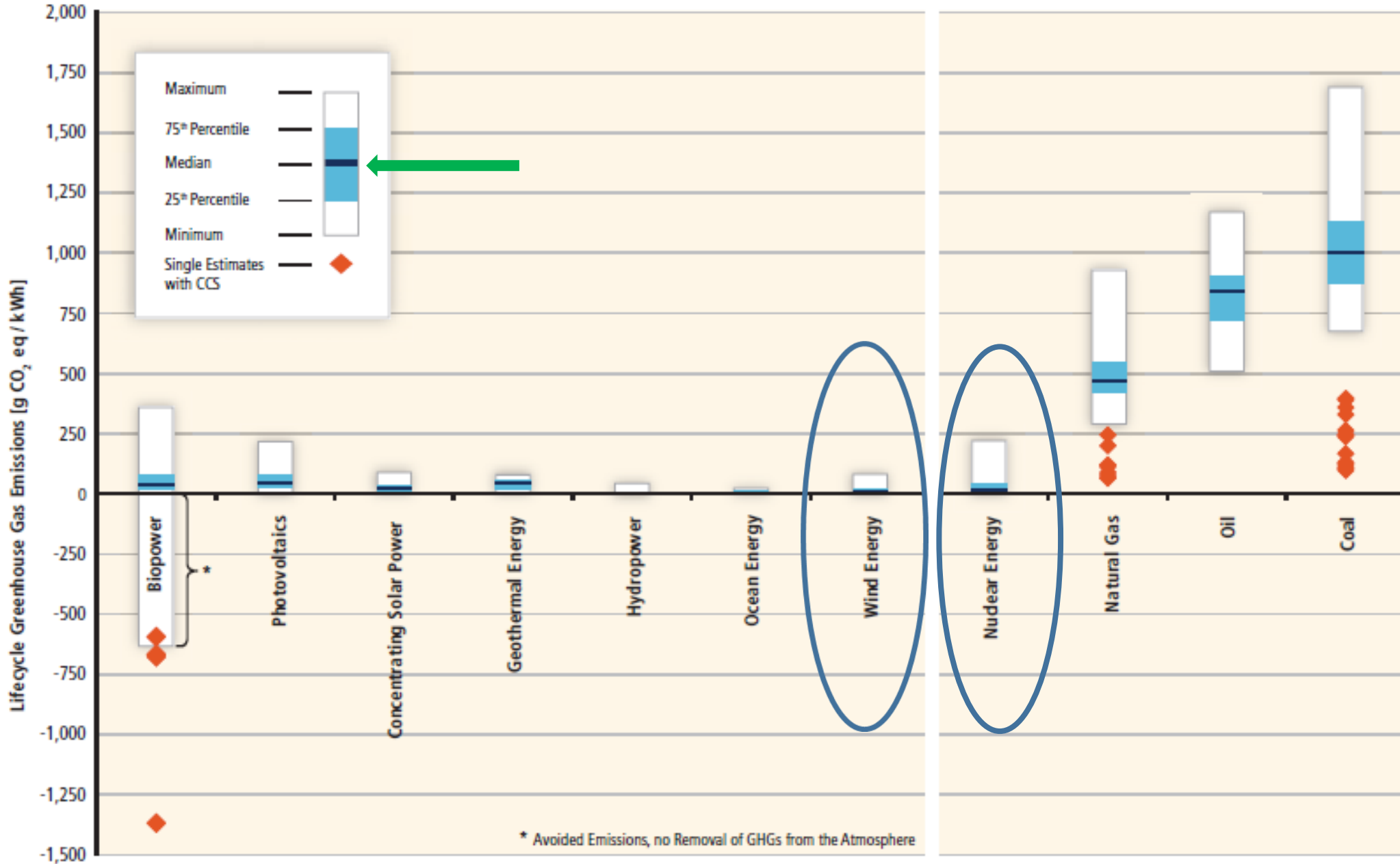

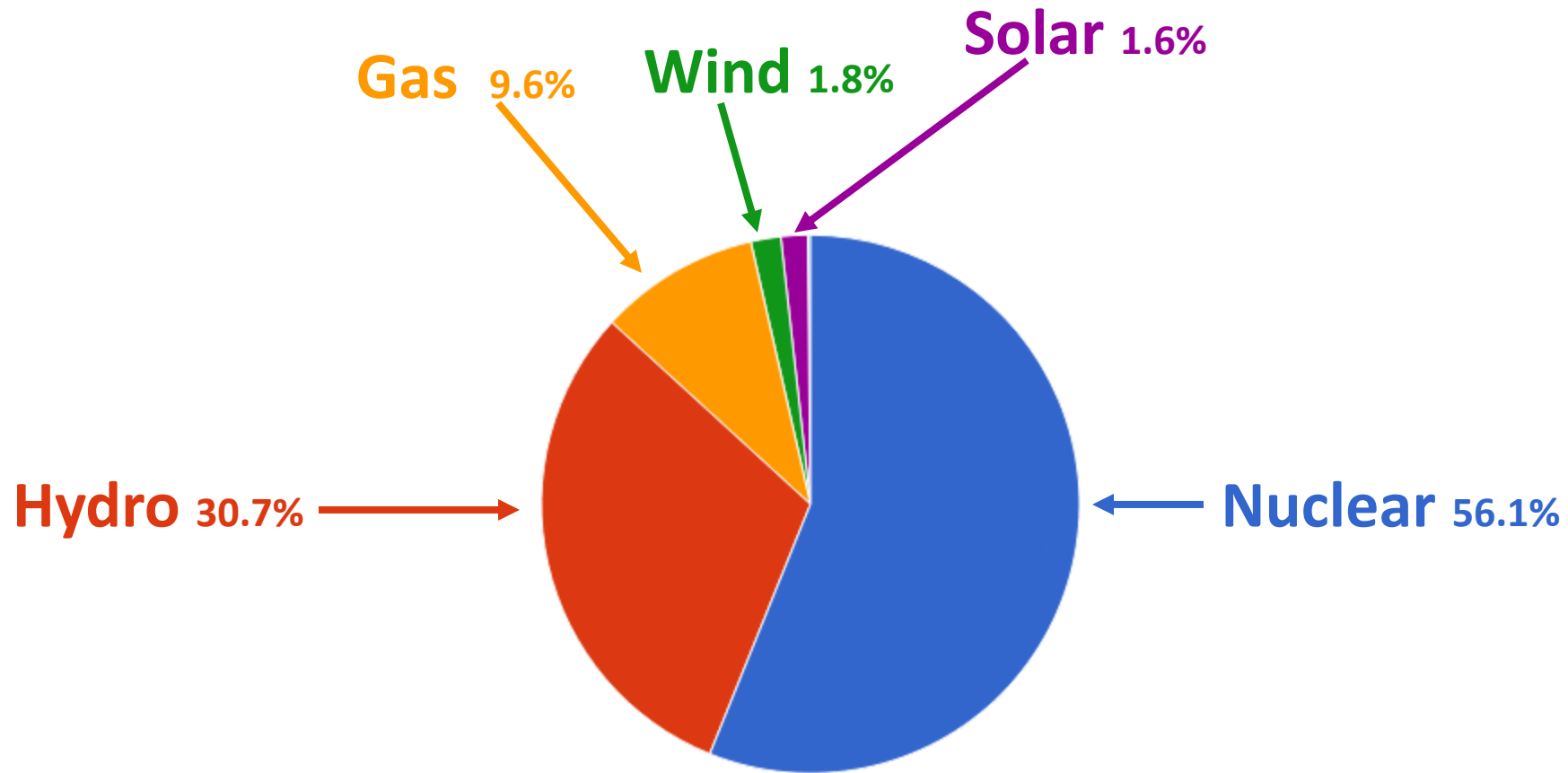

**Electricity Generated in Ontario**  
**Jun 08 2018 14:45     16,774 MW**

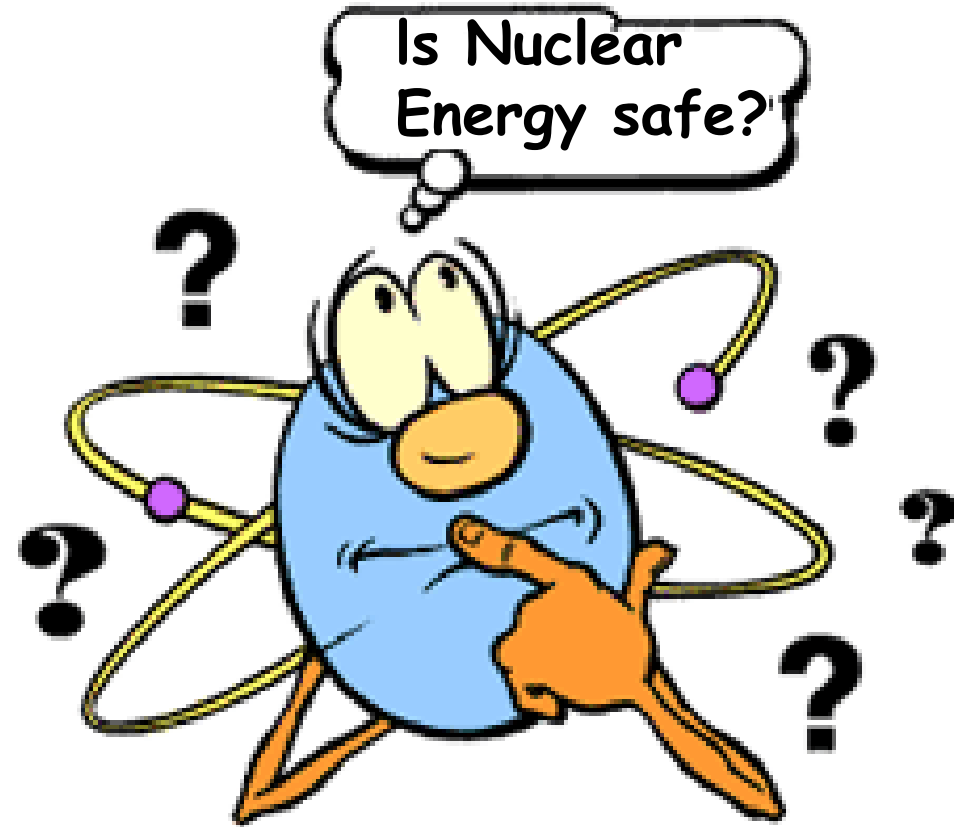

# Chernobyl



# Fukushima



# WHICH ENERGY SOURCE IS THE SAFEST?

Energy use is a necessity in the modern economy, but the practices of extracting and using energy also create a deadly trade-off.

**NUCLEAR IS SAFEST**  
Even including Chernobyl and Fukushima incidents, nuclear is the safest power source per TWh.

**A BRIGHT FUTURE**  
There are still some deaths attributable to renewables such as accidents and via lifecycle analysis, but they are among the safest forms of energy on earth.

**WATER DAMAGE**  
Hydro is normally very safe, but it has one extreme outlier that skews the data.  
In 1975, the Banqiao Dam in China collapsed during a typhoon, killing 171,000 people.

**BLACK DEATH**  
When the human and environmental costs of coal are added up, it's the biggest killer of any energy source by far.  
Air pollution alone in China kills over **4,400** people per day.

How to read this  
● = 100 Deaths  
per 1,000 TWh generated

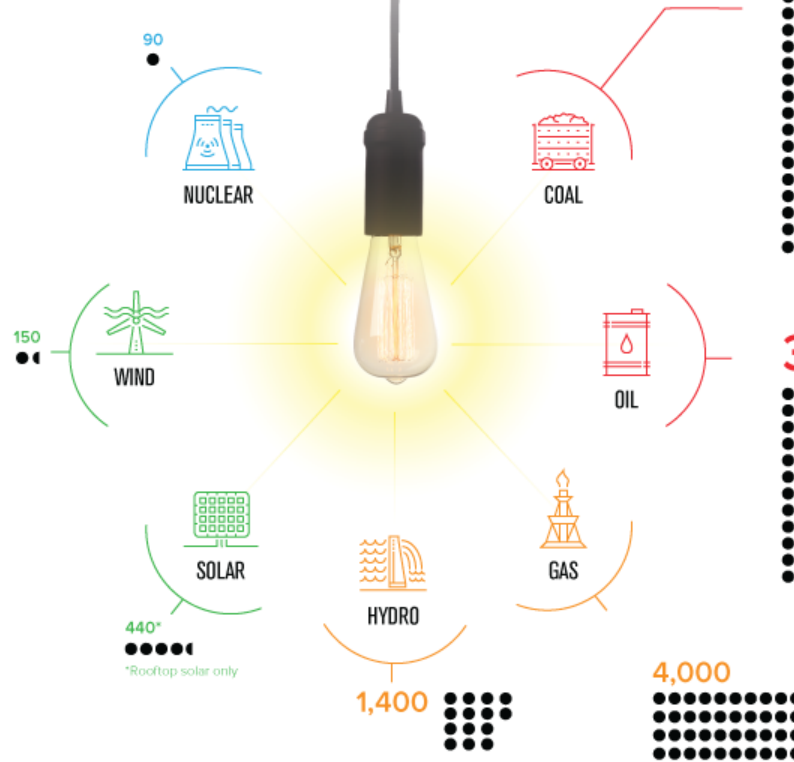

Source: Forbes

## Death rates from energy production per TWh

Death rates from air pollution and accidents related to energy production, measured in deaths per terawatt hours (TWh)

Our World  
in Data

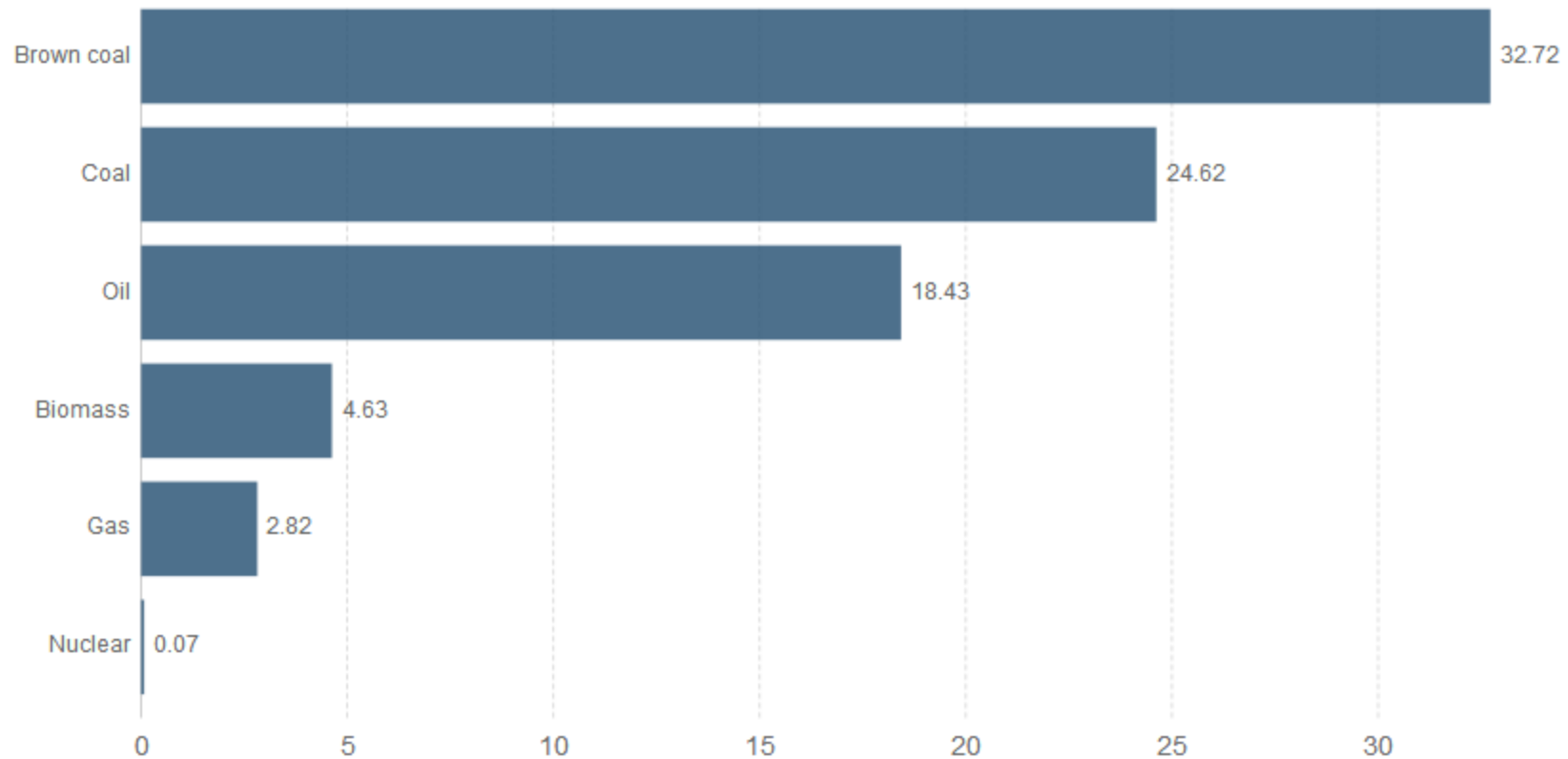

Source: Markandya and Wilkinson (2007)

Note: Figures include deaths resulting from accidents in energy production and deaths related to air pollution impacts. Deaths related to air pollution are dominant, typically accounting for greater than 99% of the total.

CHART

DATA

SOURCES



# What is safe?



# 9 dead in accidents during Quebec's holiday weekend

The Canadian Press Posted: Jun 26, 2011 1:09 PM ET | Last Updated: Jun 26, 2011 1:18 PM ET 93



A 21-year-old man was killed Sunday in an accident in Dorval. (Radio-Canada)

**Each year in Canada**  
**≈ 2,000 traffic deaths**  
**≈ 10,000 serious injuries**



**LIVE**

**BREAKING NEWS**

# QUAKE RATTLES NUCLEAR PLANTS

Nuclear safety concerns grow

**PANORAMA**  
**NEWS**  
CHANNEL

0.05

ALUM COUCHE-T 25.05 ▼ 0.30

ANVL MINING 5.33 ▲ 0.03



# Sunrise Propane Explosion - Toronto

August  
2008



Thousands evacuated from homes

Fatalities – 2

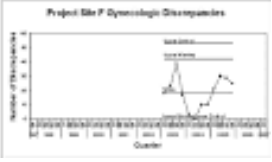
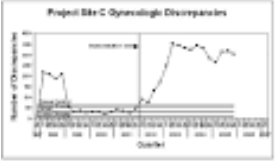
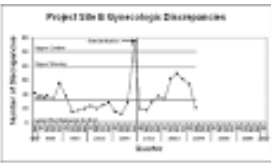
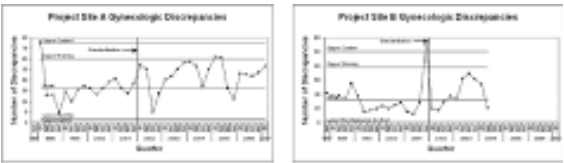

# Airliner Accident Statistics 2017

**44** airliner accident fatalities    **10** fatal airliner accidents

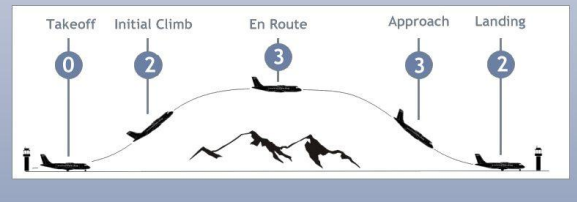
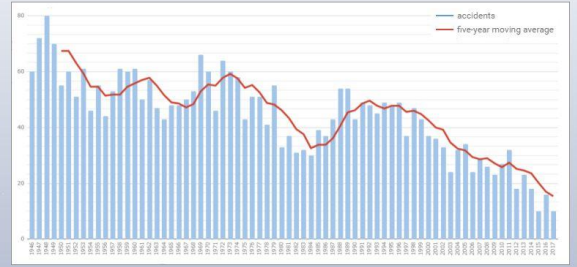

**ACCIDENTS WILL HAPPEN**  
RUSSIA AND SUB-SAHARAN AFRICA TRADE PLACES AS THE WORLD'S MOST DANGEROUS FLIGHT ZONES. AFTER RELATIVELY SAFE PASSAGE THROUGH 2009-10, RUSSIA HAS GOTTEN BAD AGAIN.

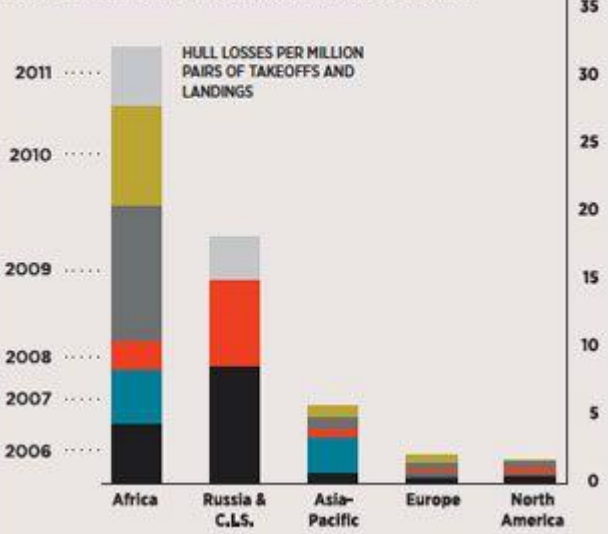

SOURCE: ASA

**55% SAFETY**  
Lorem ipsum dolor sit amet, tation soluta et cum, simu quib' voluptatibus sed ex. Ex nam omnis incidere, id invidunt reprimique consetetur mel.

**25% SAFETY**  
Lorem ipsum dolor sit amet, tation soluta et cum, simu quib' voluptatibus sed ex. Ex nam omnis incidere, id invidunt reprimique consetetur mel.

**90% SAFETY**  
Lorem ipsum dolor sit amet, tation soluta et cum, simu quib' voluptatibus sed ex. Ex nam omnis incidere, id invidunt reprimique consetetur mel.

**BUDGET**  
Lorem ipsum dolor sit amet, tation soluta et cum, simu quib' voluptatibus sed ex. Ex nam omnis incidere, id invidunt reprimique consetetur mel.

**DESTINATION**  
Lorem ipsum dolor sit amet, tation soluta et cum, simu quib' voluptatibus sed ex. Ex nam omnis incidere, id invidunt reprimique consetetur mel.

**CONFORT**  
Lorem ipsum dolor sit amet, tation soluta et cum, simu quib' voluptatibus sed ex. Ex nam omnis incidere, id invidunt reprimique consetetur mel. Ex nam cibo

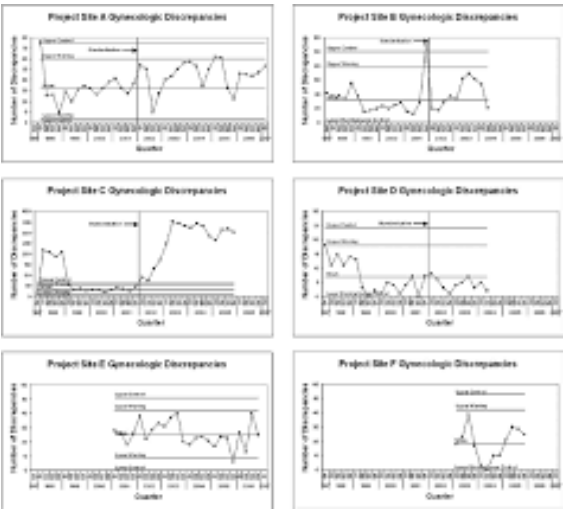

## Airliner Accident Statistics 2017

**44** airliner accident fatalities    **10** fatal airliner accidents

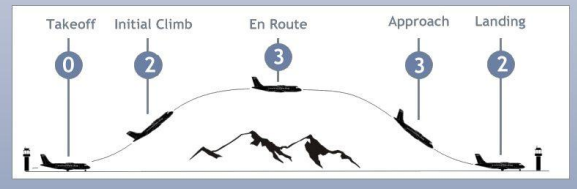
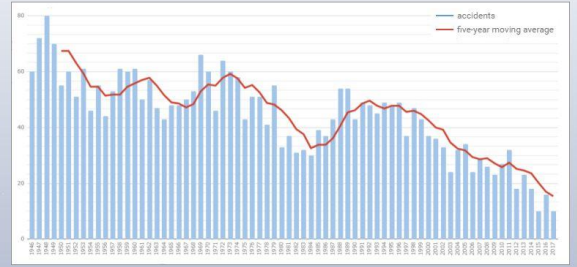

**ACCIDENTS WILL HAPPEN**  
 RUSSIA AND SUB-SAHARAN AFRICA TRADE PLACES AS THE WORLD'S MOST DANGEROUS FLIGHT ZONES. AFTER RELATIVELY SAFE PASSAGE THROUGH 2009-10, RUSSIA HAS GOTTEN BAD AGAIN.

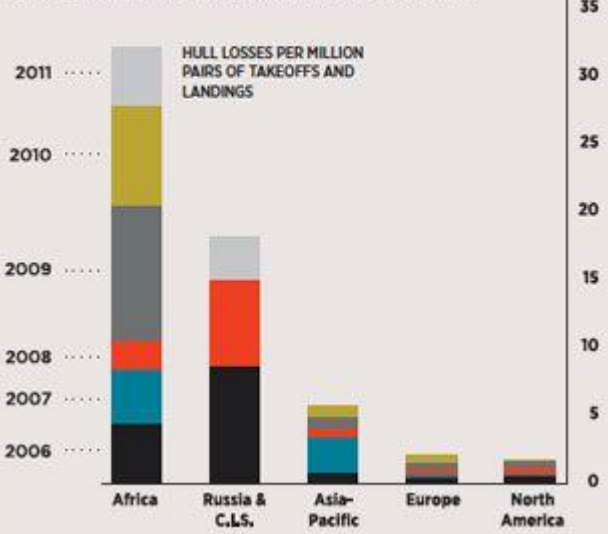

SOURCE: ASA



*Nothing in life is to be feared, it is only to be understood. Now is the time to understand more, so that we may fear less.*

*Marie Curie*





**1966 Chev Impala**

**24 major safety improvements**



**2017 Chev Impala**

- ✓ Inertial reel 3 pt. seat belts
- ✓ Radial tires
- ✓ Disk brakes
- ✓ Air bags
- ✓ Dual diagonal braking circuits
- ✓ Anti-lock brakes
- ✓ Backup camera & warning alarm{
- ✓ Traction control
- ✓ Dynamic Stability Control
- ✓ Auto dimming rear view mirror
- ✓ Daytime running lights
- ✓ Third brake light
- ✓ Rear window defogger
- ✓ Articulating headlights
- ✓ Anti theft system-ignition interlock
- ✓ Enhanced corrosion control
- ✓ Advanced emissions control
- ✓ Automatic headlights
- ✓ Energy absorbing crumple zones
- ✓ Data recorders
- ✓ Engine drop on impact
- ✓ Impact fuel shutoff
- ✓ Hands free controls
- ✓ Radar activated emergency braking





**Defense in Depth** is creating multiple independent, and redundant, layers of prevention, protection, and response, to failures, accidents, or fires in power plants.

This concept shall be applied throughout the design process and operation of the plant to provide a series of levels of defence aimed at preventing accidents, and ensuring appropriate protection in the event that prevention fails.

# Tests done on HTR-10

- *Loss of helium flow*

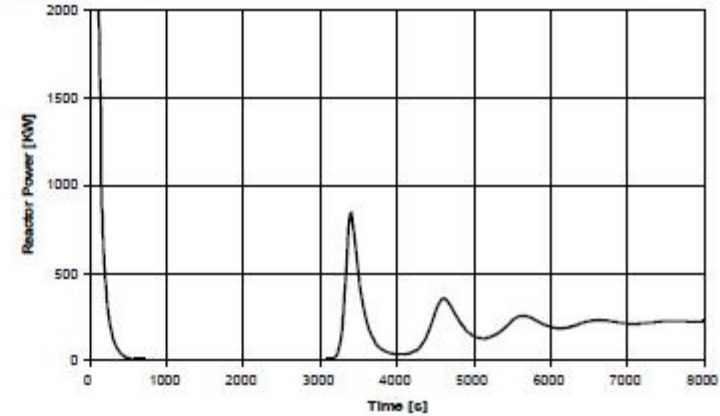

**Negative thermal reactivity coefficient**



## Negative thermal reactivity response to loss of coolant

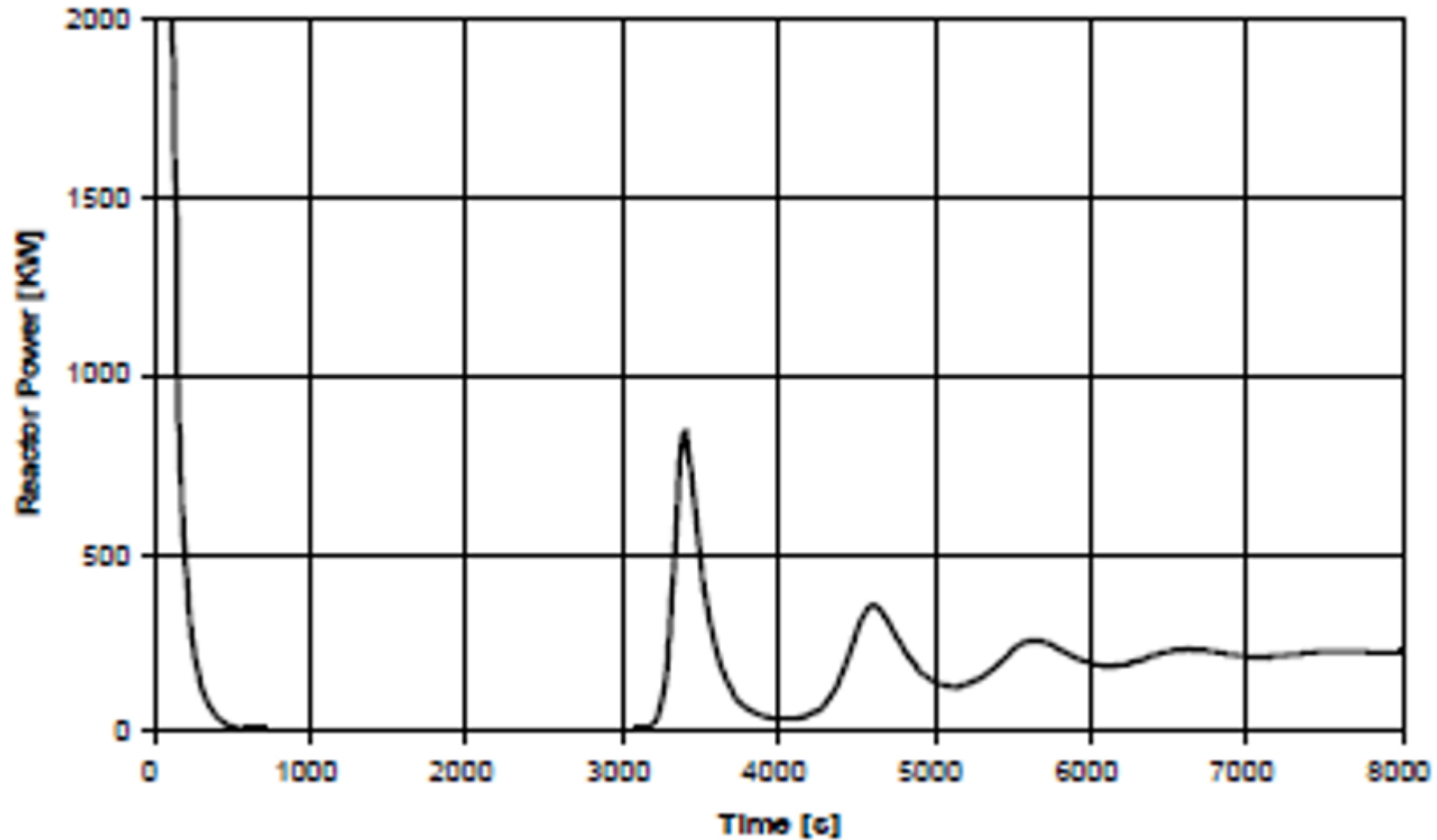

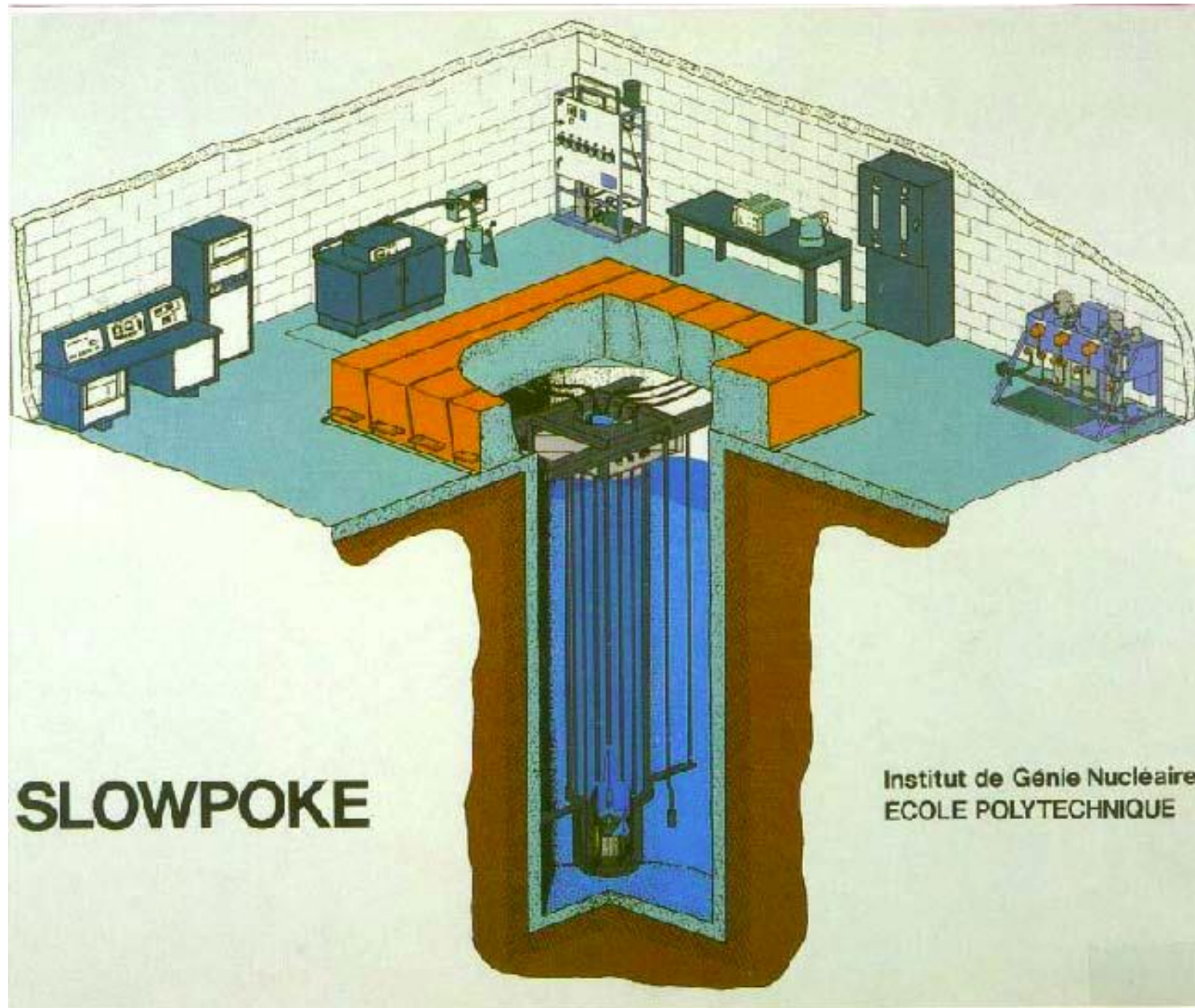

**SLOWPOKE**

Institut de Génie Nucléaire  
ECOLE POLYTECHNIQUE

# CANDU nuclear fuel

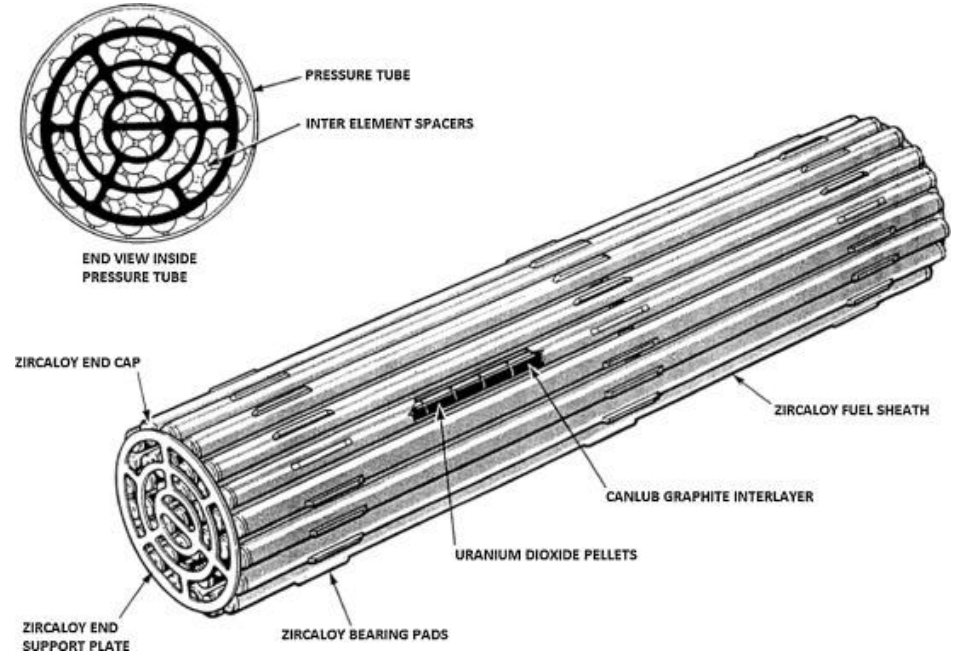

## TRISO Fuel Compact

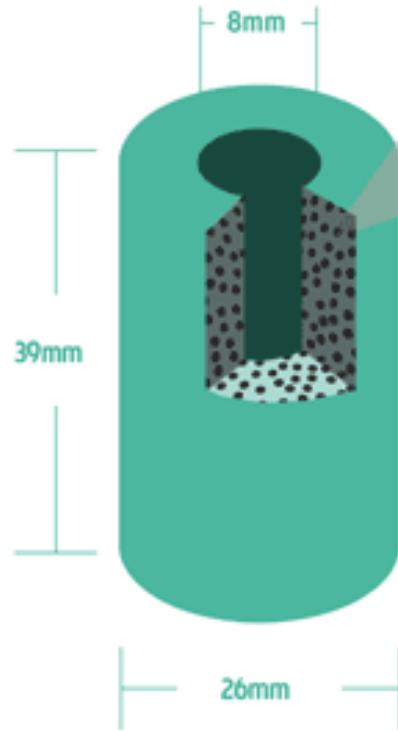

## TRISO Coated Fuel Particle

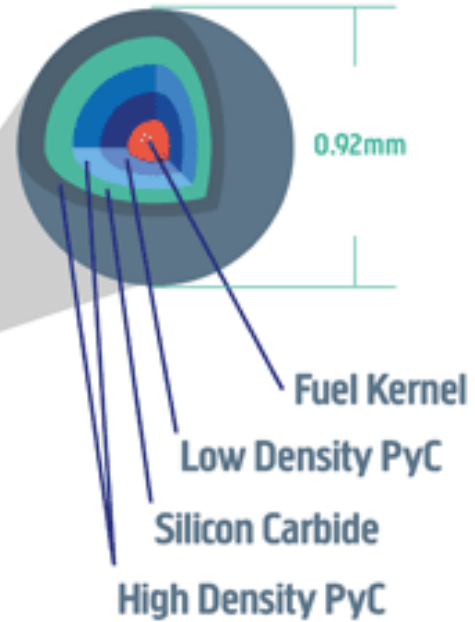

TRISO fuel is constructed by triple coating spherical particles of uranium fuel. A uranium centre is coated in a layer of carbon, which in turn is coated in silicon carbide, with a further outer layer of carbon.

The structure and spherical shape of TRISO fuel means that it maintains its integrity under extreme conditions. Research has shown that even at temperatures of up to 1800°C (200°C hotter than assumed accident conditions) the majority of fission products remain inside the TRISO fuel particles, significantly enhancing safety.

TRISO fuel is based on proven technology. It was originally developed in the 1980s and is currently being manufactured in the USA.

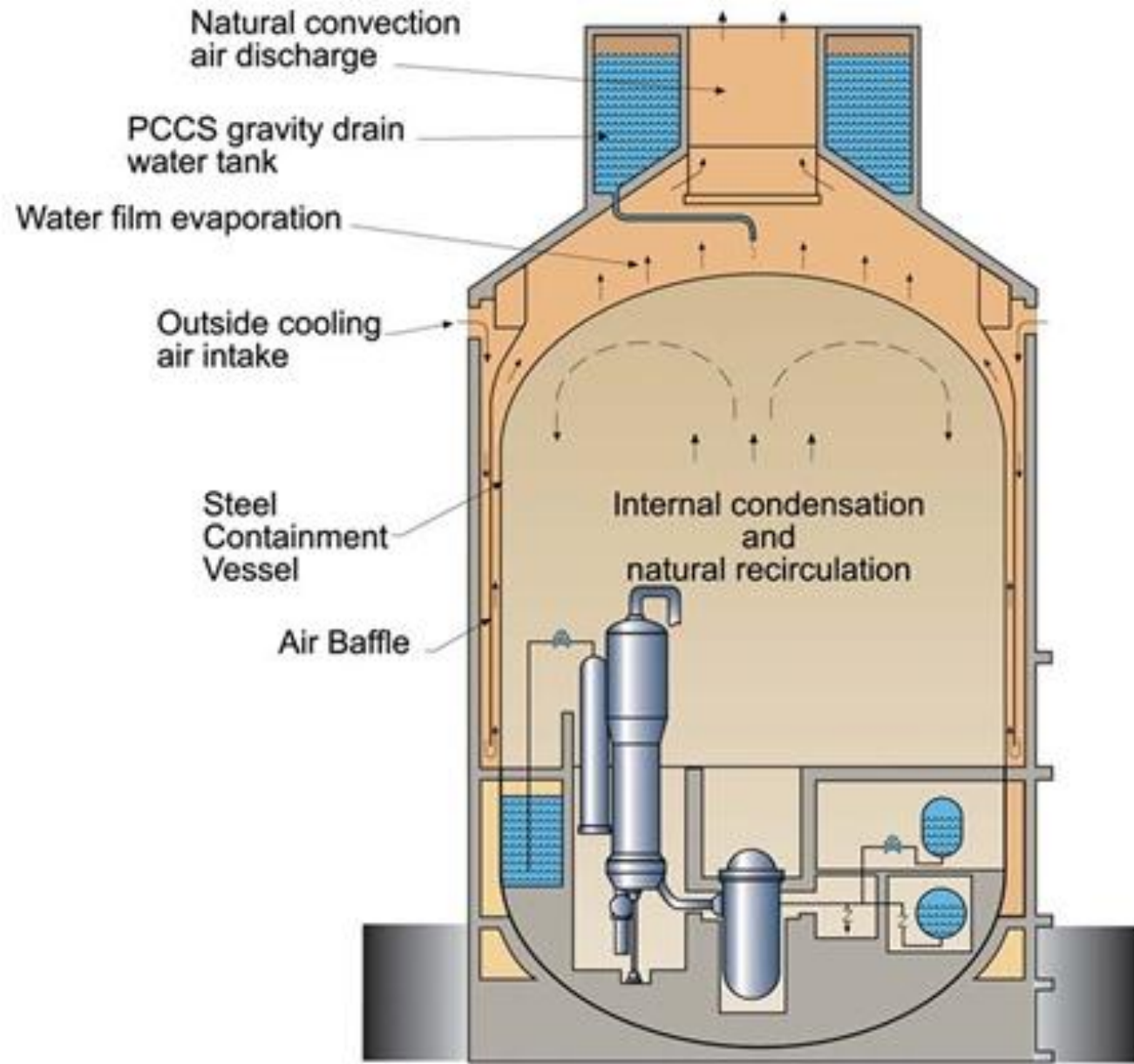

AP1000 Passive Containment Cooling System

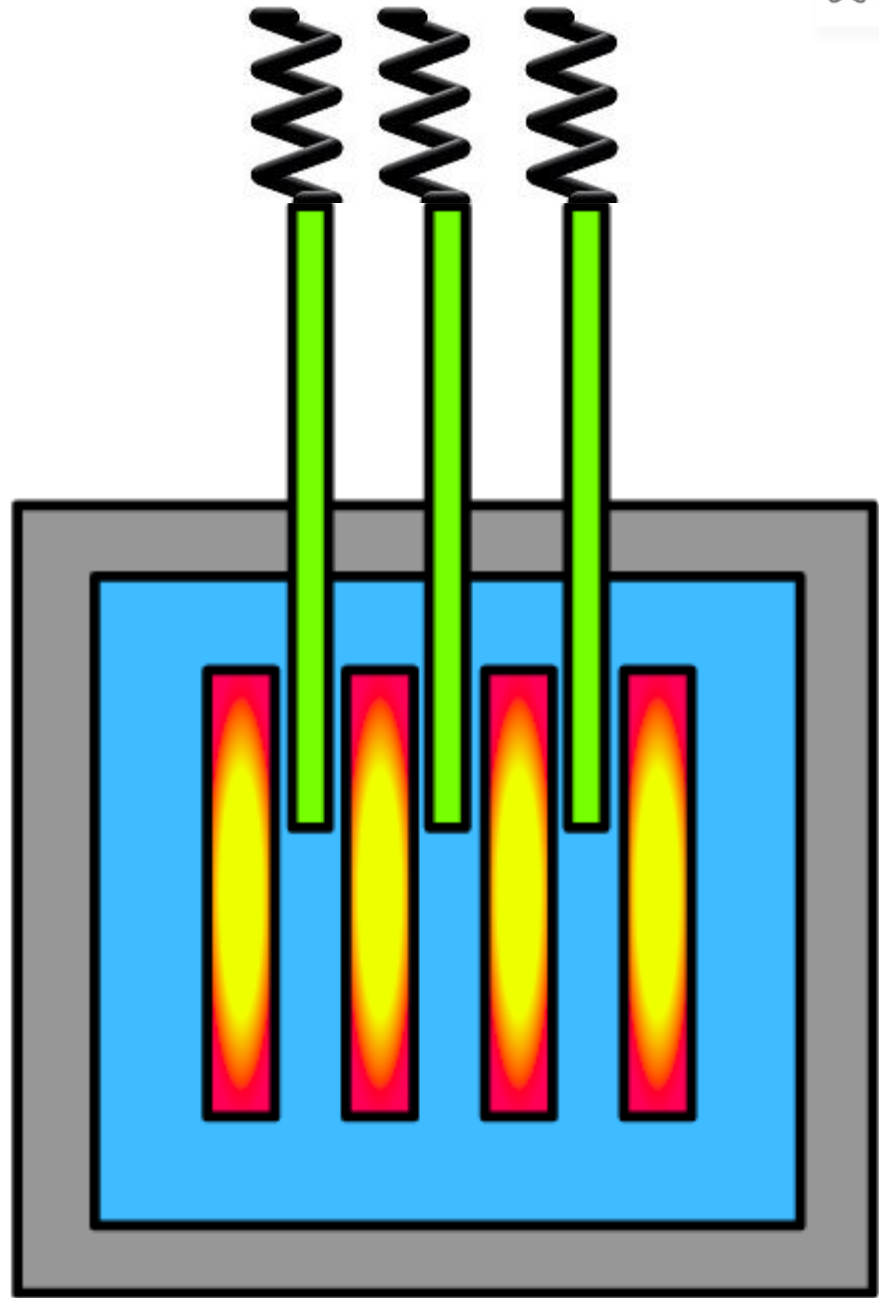
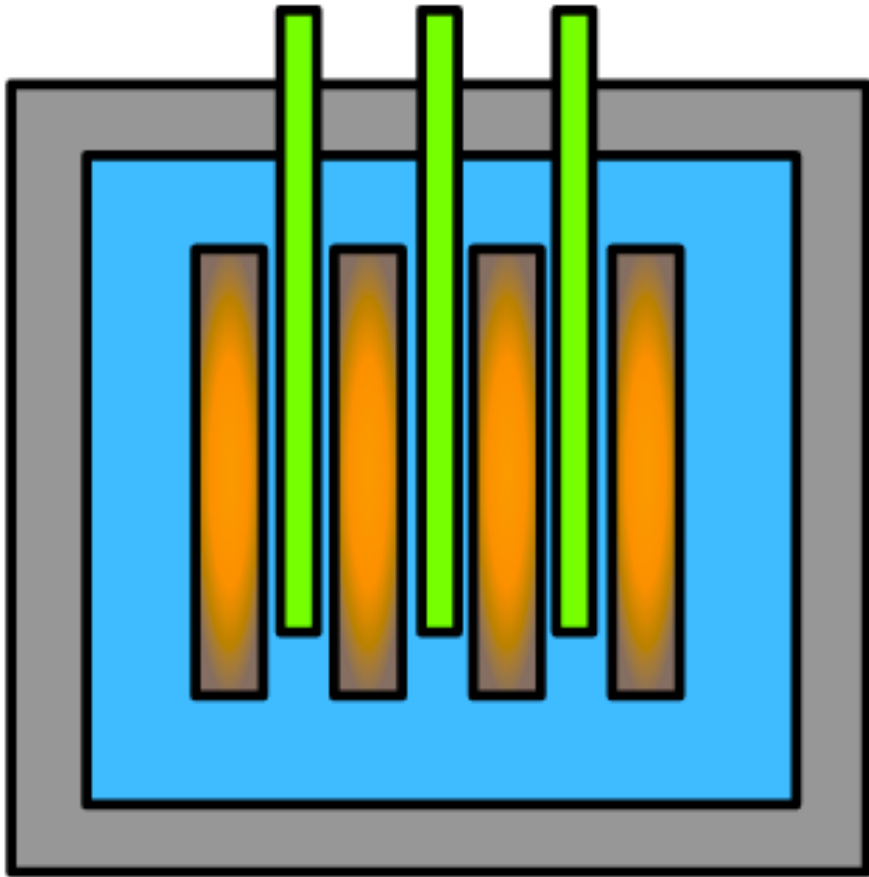

Our priority is protecting people  
and the environment

[Explore Canada's Plan for used nuclear fuel »](#)

Which areas are involved?

[Learn More »](#)

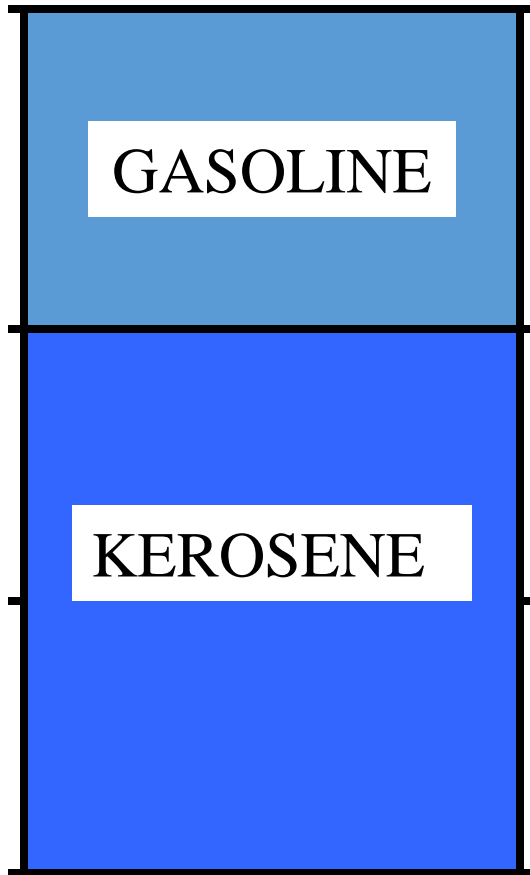

**Crude Oil**  
**Refining 1890**

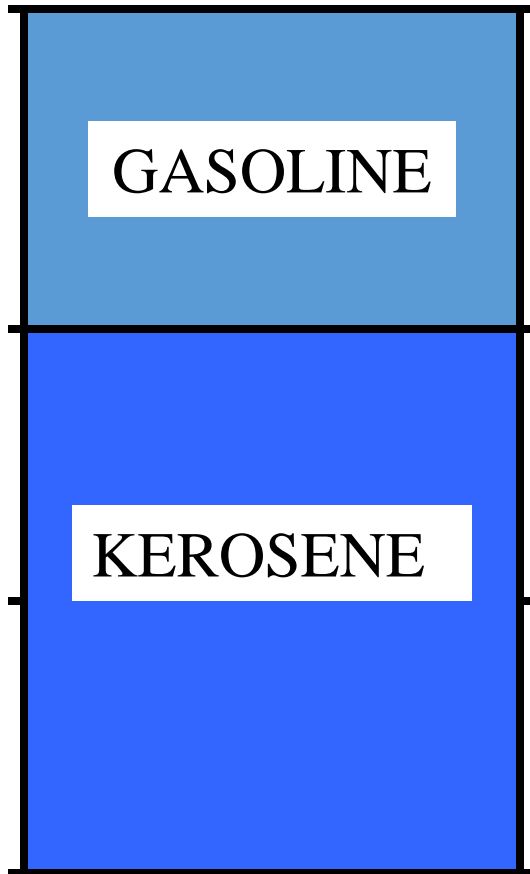

**Crude Oil  
Refining 1890**

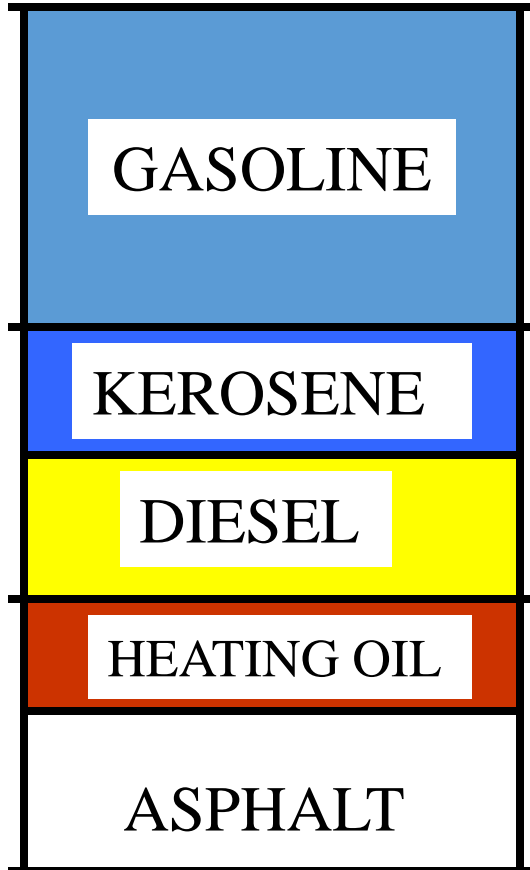

**Crude Oil**

**Refining 2018**

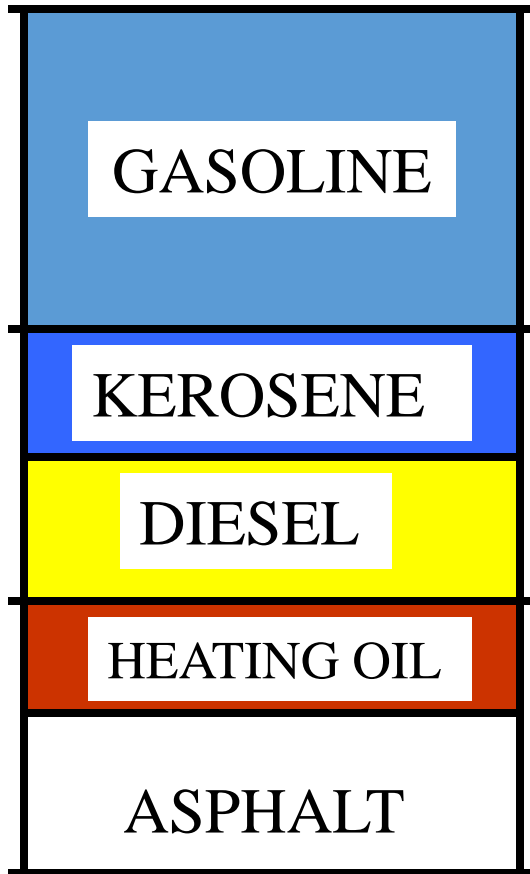

**Crude Oil**

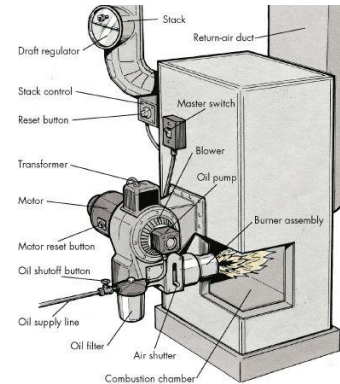
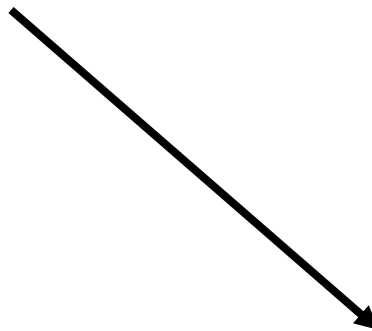

**0.7% U235**

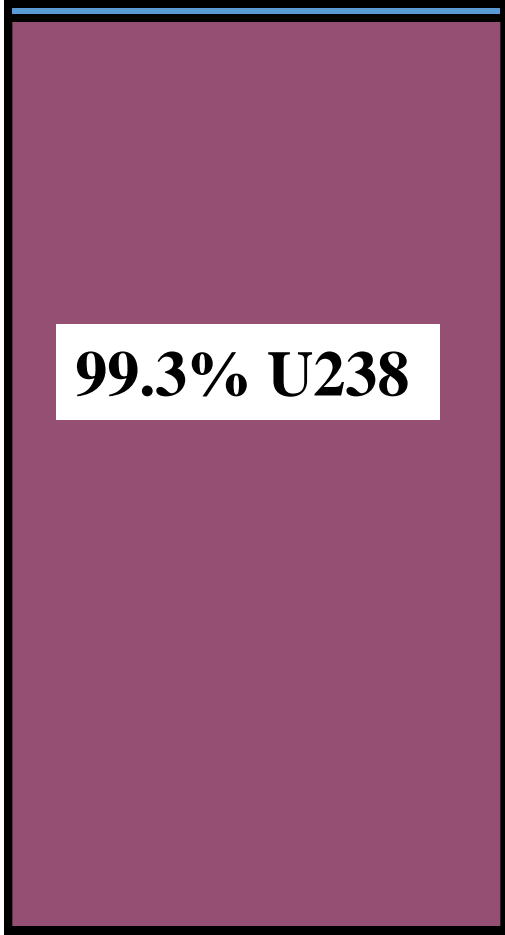

**99.3% U238**

**Natural Uranium**

**0.7% U235**

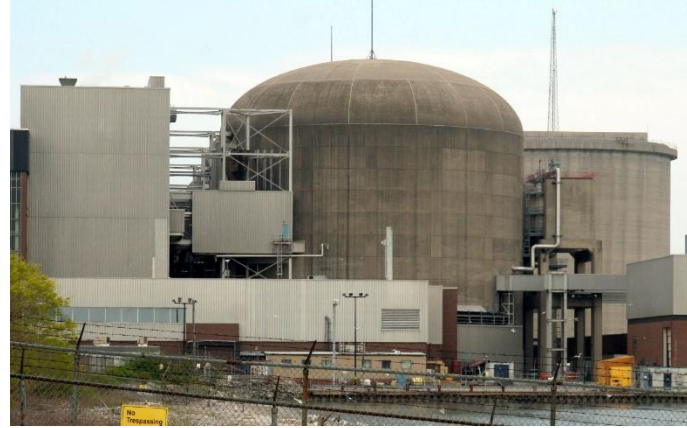
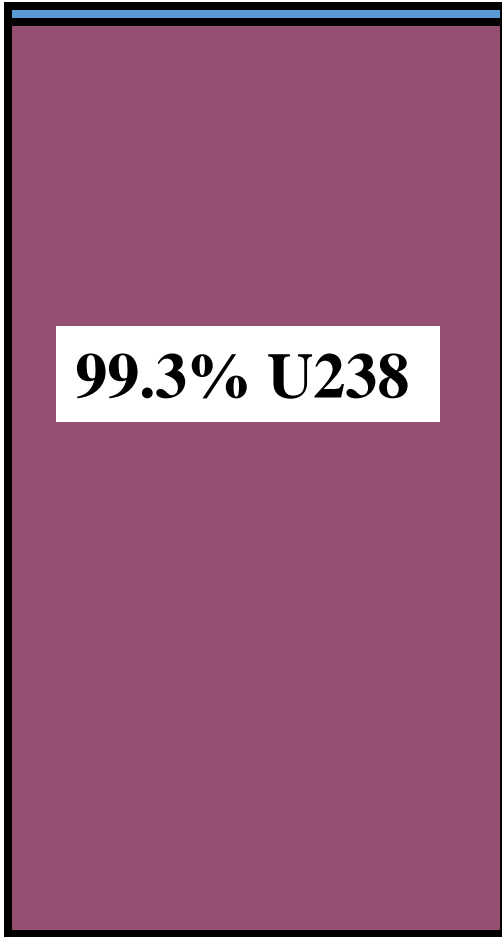

**Pickering – thermal reactor**

**Natural Uranium**

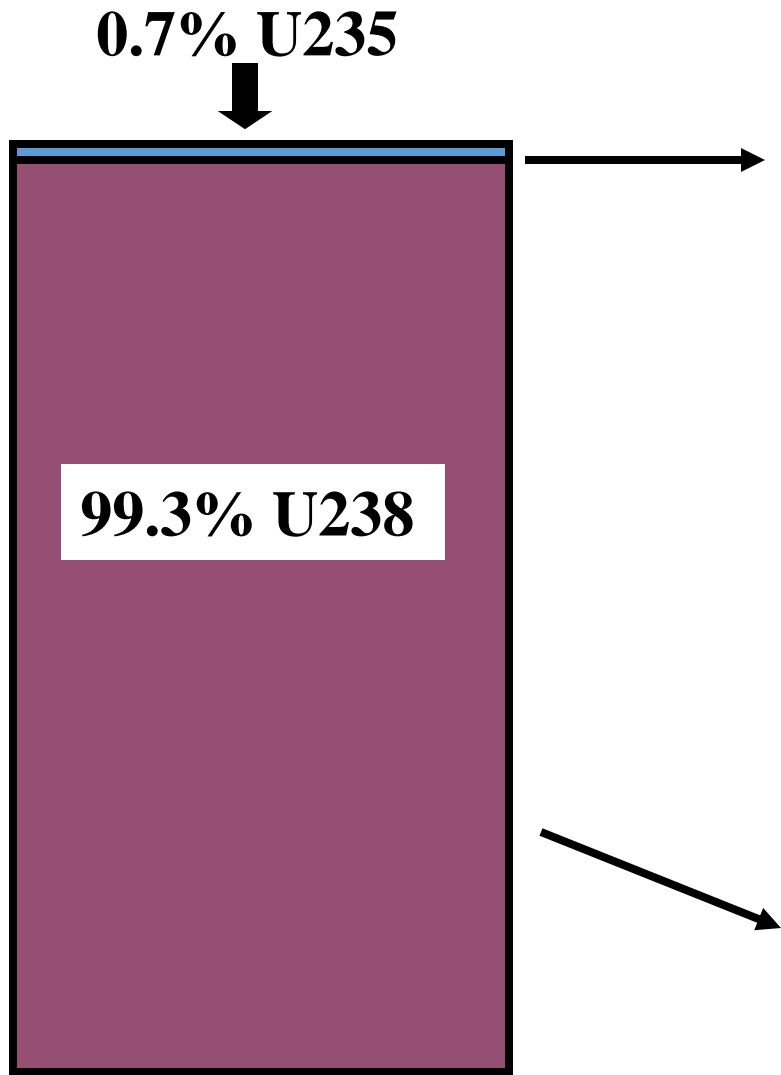

**Natural Uranium**

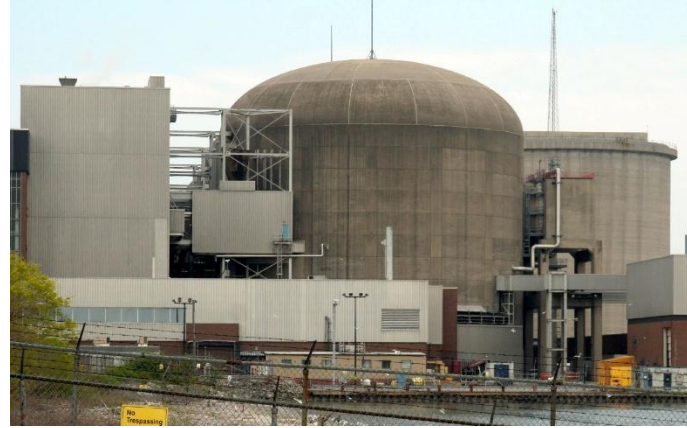

**Pickering – thermal reactor**



**EBR-2 – fast reactor**



This glass disc simulates the amount of vitrified waste produced by one person in a lifetime if all his electricity was produced by nuclear energy.







Canada's Plan	
<b>About Adaptive Phased Management</b>	<b>-</b>
Implementing the Plan	+
Employment and Economics	
Selecting APM: A Three-Year Study	+
Canada's Used Nuclear Fuel	+
What Other Countries Are Doing	+

# About Adaptive Phased Management



Adaptive Phased Management (APM) is the name of Canada's plan for the long-term management of [used nuclear fuel](#).

APM emerged from a [three-year dialogue](#) with both specialists and the general public. It is consistent with long-term management best practices adopted by other countries with nuclear power programs, such as Finland, France, Sweden, Switzerland, and the United Kingdom.

The federal government selected APM as Canada's plan in June 2007. The NWMO is now responsible for implementing APM, subject to all necessary [regulatory approvals](#).

## Components of Adaptive Phased Management

APM is both a technical method and a management system.

The end point of the technical method is the centralized containment and isolation of Canada's used fuel in a [deep geological repository](#) in an area with suitable geology and an informed and willing host. APM also involves the development of a [transportation system](#) to move the used fuel

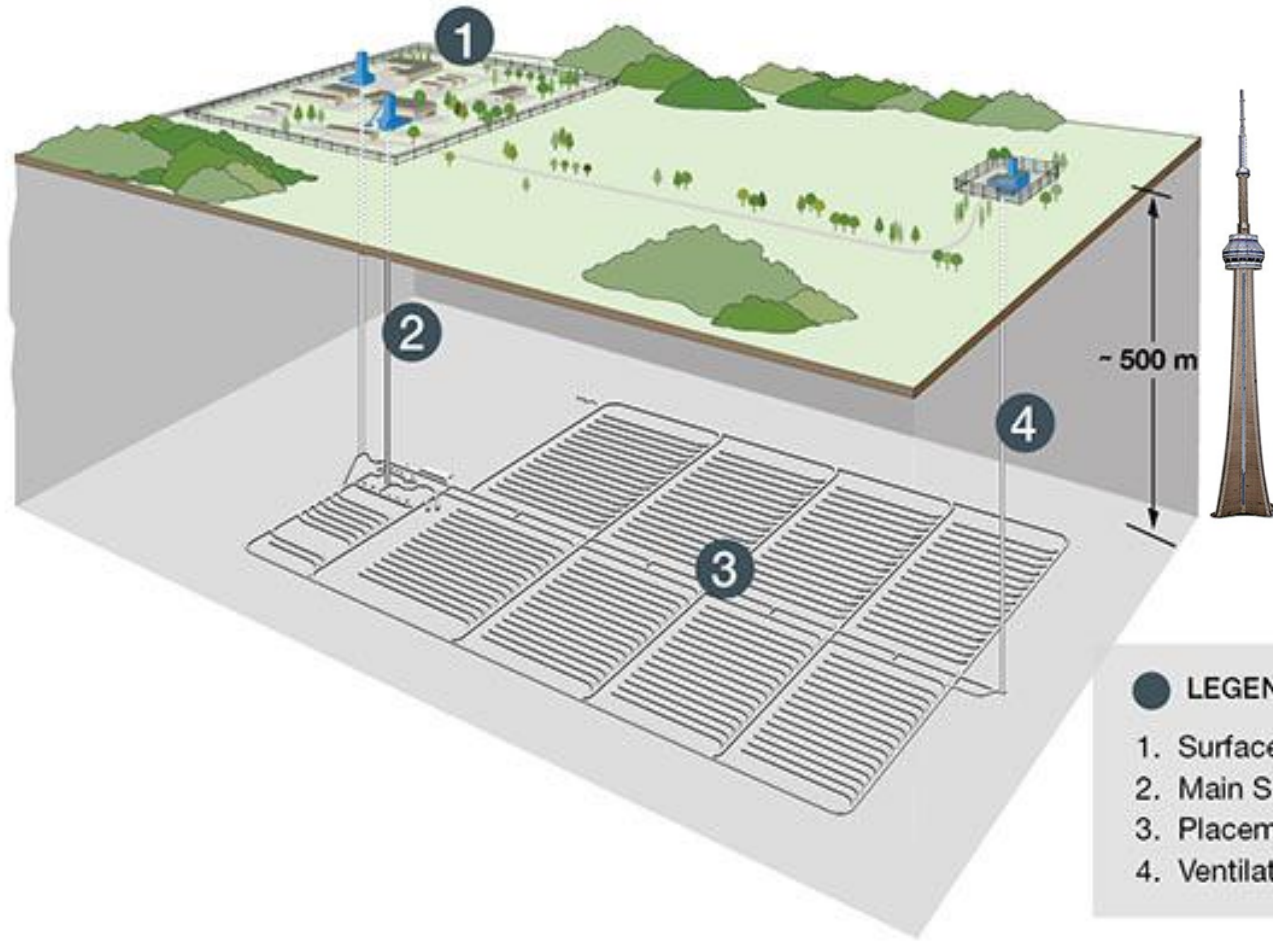

- **LEGEND**
- 1. Surface Facilities
  - 2. Main Shaft Complex
  - 3. Placement Rooms
  - 4. Ventilation Exhaust Shaft

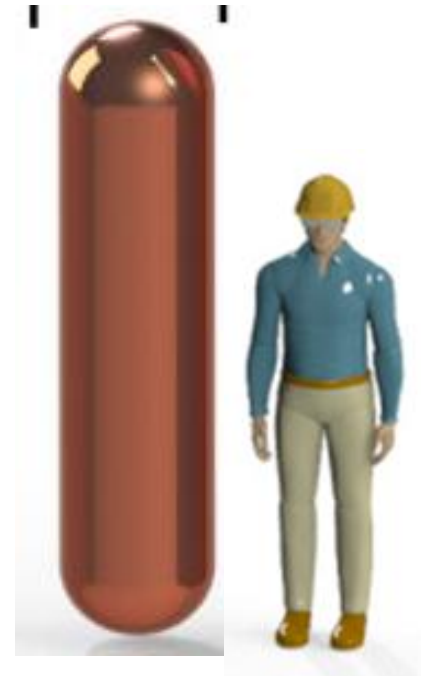
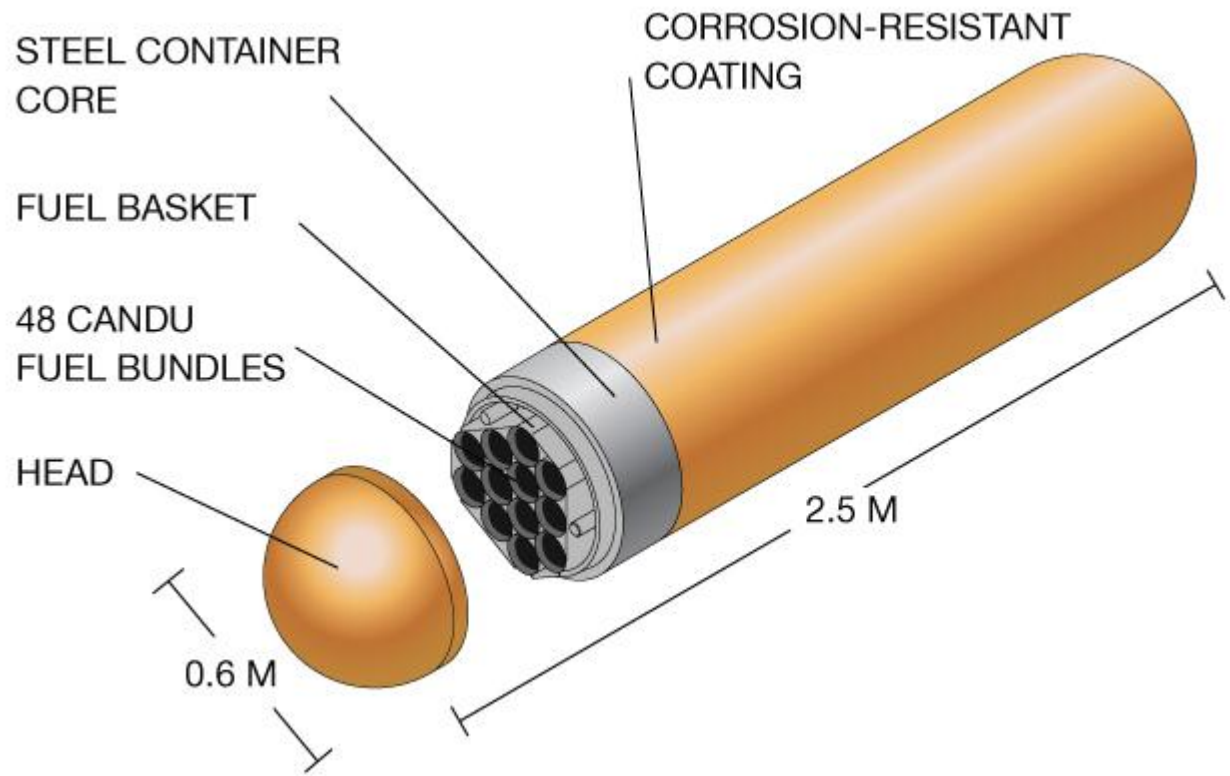

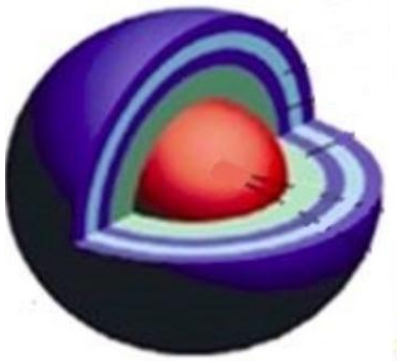

Spent Fuel Container

Bentonite Clay

Rock

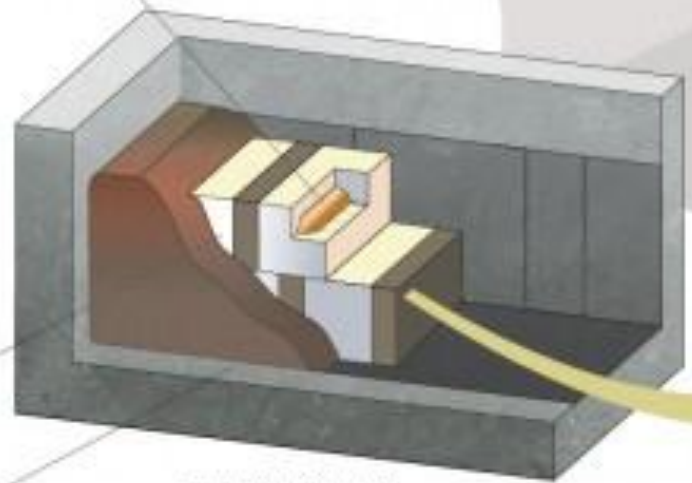

Lateral Tunnel Approach

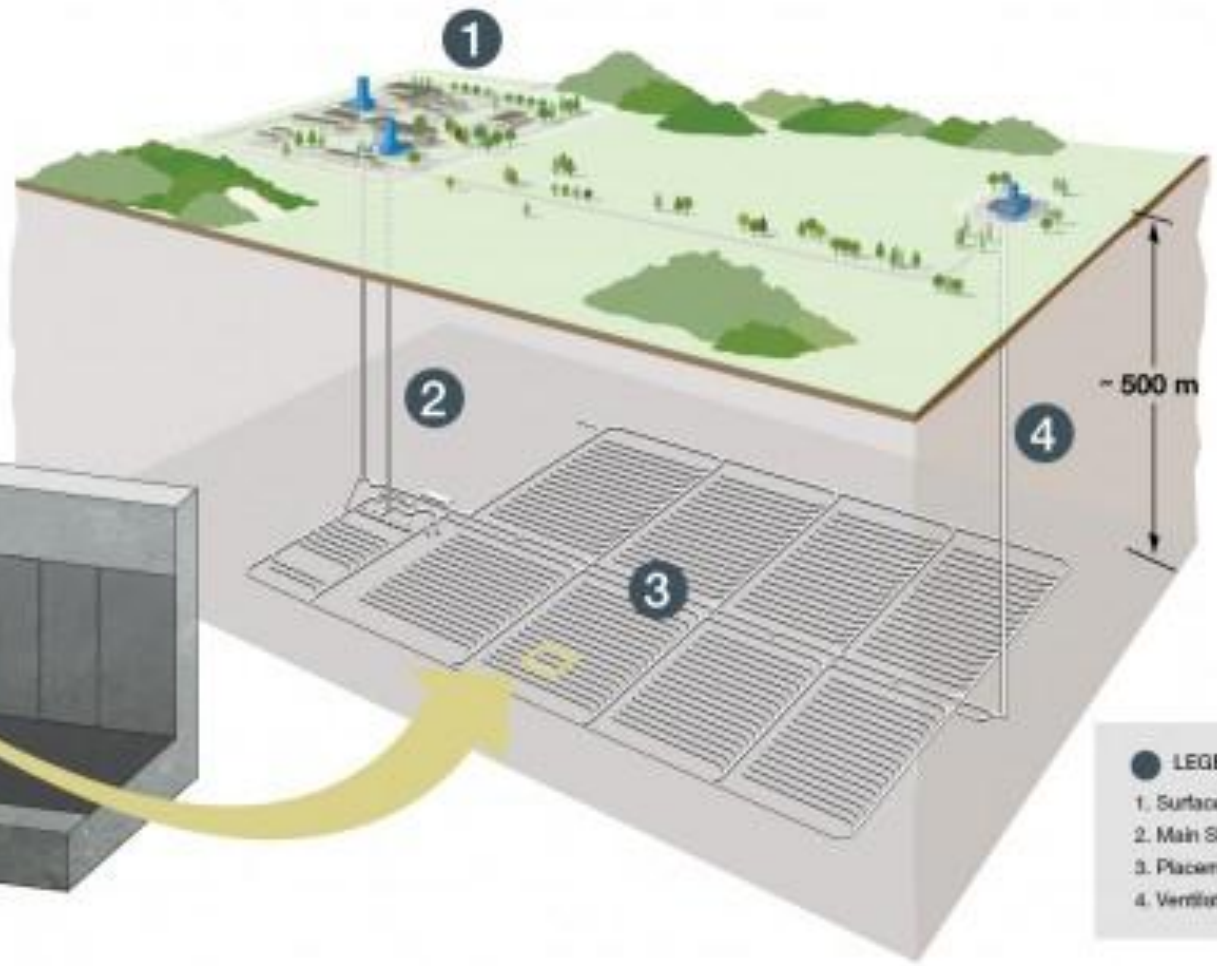

- LEGEND**
- 1. Surface Facilities
  - 2. Main Shaft Complex
  - 3. Placement Rooms
  - 4. Ventilation Exhaust Shaft

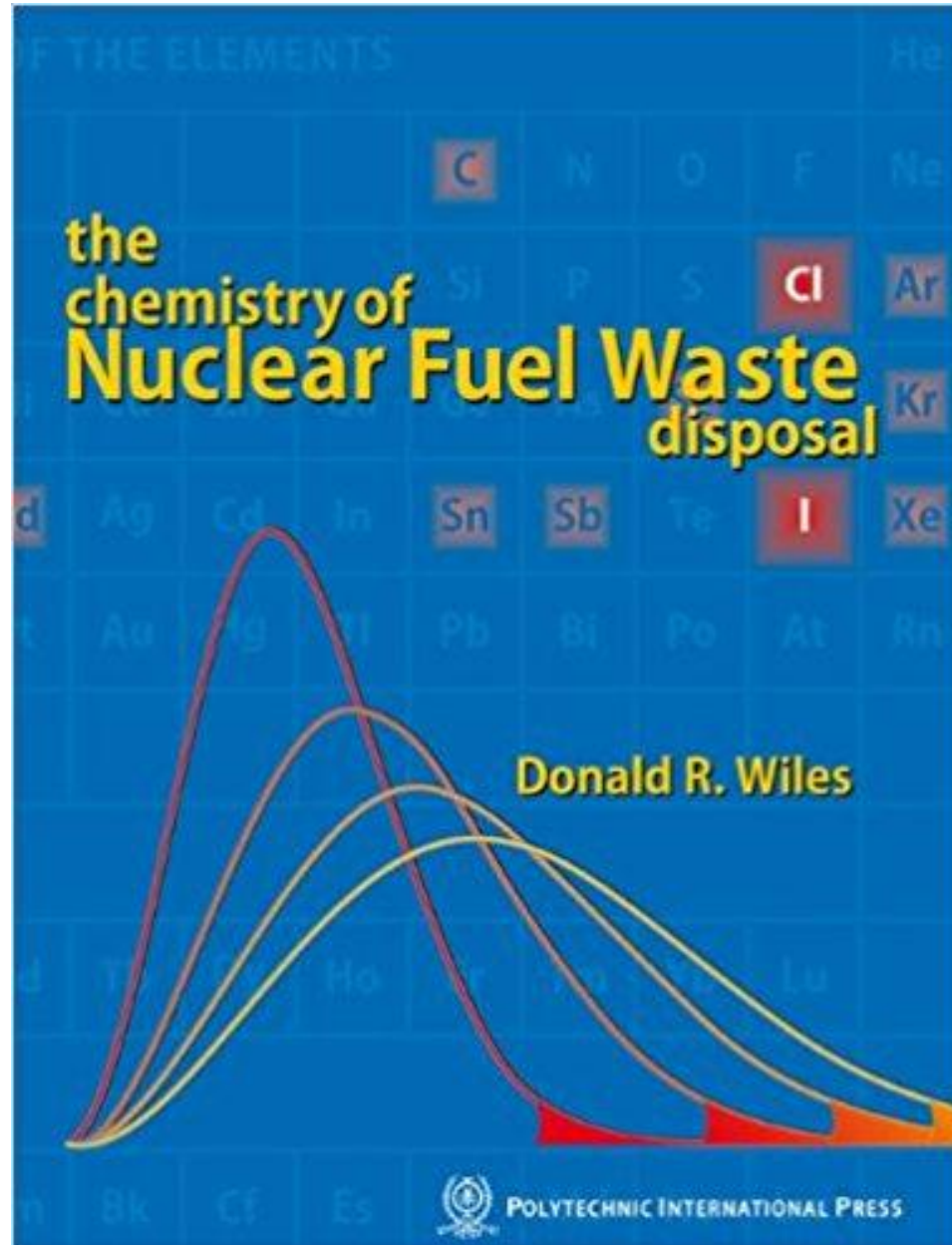

## Airships to electric roads: Searching for the boldest idea for building Canada

Inzem Energy: A series of small, modular nuclear reactors could be developed that would consume – and thereby reduce – Canada’s existing nuclear-waste stockpiles, creating thousands of jobs and helping the country meet its energy needs for decades or centuries to come, according to nuclear-power experts Paul Acchione, Peter Ottensmeyer and Charles Rhodes.

**Inzem Energy:** A series of small modular nuclear reactors could be developed that would consume – and thereby reduce – Canada’s existing nuclear-waste stockpiles...



**Bilibino, Pop. 5,500**



**Gold Mine**



**Nuclear Heated Green House**





**LIVE**

**BREAKING NEWS**

# QUAKE RATTLES NUCLEAR PLANTS

Nuclear safety concerns grow

**NEWS**  
CHANNEL

0.05

ALUM COUCHET 25.05 ▼ 0.30

ANVL MINING 5.33 ▲ 0.03





## Further information sources

Canadian Nuclear Society <https://www.cns-snc.ca/>

Canadian Nuclear Association <https://cna.ca/>

International Atomic Energy Agency <https://www.iaea.org/>